

BELLCOME
TL Touch Line

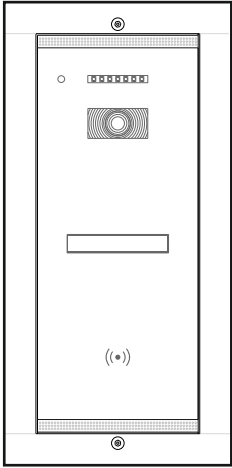

1 Fam. Video

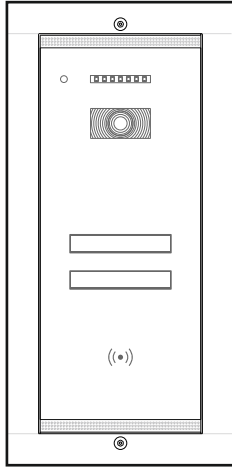

2 Fam. Video

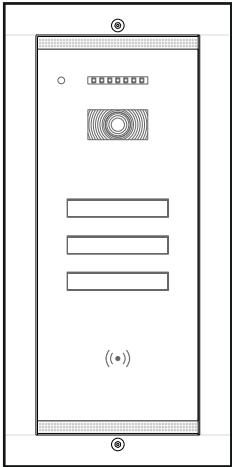

3 Fam. Video

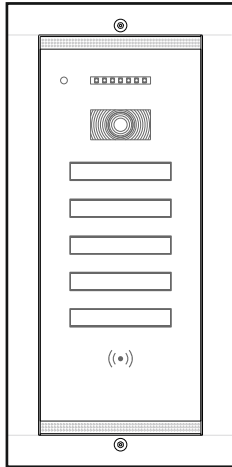

5 Fam. Video

VIDEO OUTDOOR PANELS
(1 – 5 Families)
for TL door phone systems
User manual

EN

0 EN Contents

- | | |
|-------------------------------------------|-------------------------------------------|
| 1 Safety instructions | 5 Use of the video outdoor panels |
| 2 Description of the video outdoor panels | 6 Maintenance of the video outdoor panels |
| 3 Functions of the video outdoor panels | 7 Warranty |
| 4 Recommended cables. Installation | |

1 EN Safety instructions



Any intervention on the installation must be performed by AUTHORIZED PERSONNEL!

DO NOT power the product at 110 – 230 Va.c.!

DO NOT hit the glass screen with hard objects!

If the glass screen is broken, DO NOT touch the product.

Protect the products against lime and dust during renovation activities.



2 EN Description of the video outdoor panels

EN
1

Video outdoor panel	
VPA.1FR02	VPA.2SR02
294 x 144 x 53 mm	260 x 110 x 33 mm
1,52 kg	1,3 kg
- 30°C ... + 60°C	
IP44	
+U = 12 ... 14 Vd.c.	
Access – RFID card	

Video outdoor panel	
VPA.3FR02	VPA.5SR02
294 x 144 x 53 mm	260 x 110 x 33 mm
1,52 kg	1,3 kg
- 30°C ... + 60°C	
IP44	
+U = 12 ... 14 Vd.c.	
Access – RFID card	

- Case: aluminum + 4 mm chemically toughened glass
- 70° ± 25° orientable video camera
- CMOS, 1/3", 573(H) x 597(V), 800 TVL video 1 Vpp / 75 W; PAL
- IR LEDs, 850 nm, IR-CUT for night vision - 10m
- TOUCH keys for call and family name, backlit during night
- Wall mounting height: **160 cm**

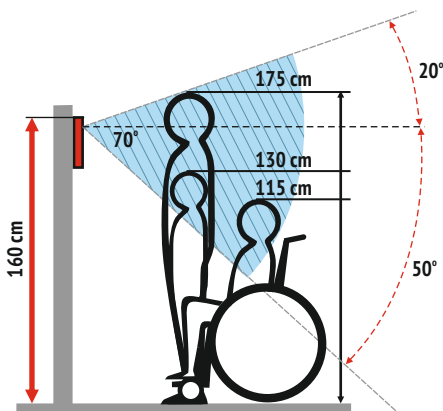

3 EN Functions of the video outdoor panels

Build features:

- Solid mechanical construction, built in embedded technology, with chemically toughened glass.
- Weatherproof, waterproof and with an operating temperature range between -30°C ...+ 60°C .
- Electronic anti-condensation system for the video camera screen.
- Anti-theft sensor that is activated during unauthorized unmounting from the wall.
- Day/night sensor for the command of TOUCH keyboard backlighting and the lighting of the IR LEDs and IR-CUT.
- TOUCH keyboard with the name of the resident, backlit during night.
- 1/3 CMOS, 900TVL color video camera and IR LEDs for b/w image during night.
- Blinking red LED, signaling the presence of potential video monitoring from the panel.
- In-built RFID reader. Access by secured RFID tag/card.
- Allows the connection of a DVR, for extended monitoring and video recording from the panel.

Settings/Programming

- Programming and deletion of RFID building access tags/cards.
- Programming of new address 2, 3 or 4, for parallel connected panels, in case of buildings with multiple entrances. (maximum 4 outdoor panels for one building).
- Enabling or disabling of video monitoring signaling (Red LED ON/OFF), through the **JP1: RED LED/0. (ch. 4.1-step 4)**
- Enabling or disabling DVR video recording (ON/OFF) through the jumper **JP40: 1-2 (OFF) / 2-3(ON) (ch. 4.1)**

Extensions

- Allows the parallel connection of maximum 4 outdoor panels, through a video selection box (VSB).
- Allows the connection of an additional video camera directly to the central supply unit (SCU), or of 4 additional video cameras, through a video selection box (VSB).

EN
2

4 EN Recommended cables. Installation.

- **4 wires x 0.5 mm²** (type **H03VV-F4G 0.5**) for maximum **75 ml** or another type of equivalent cable
- **4 wires x 0.75 mm²** (type **H05VV-F4G 0.75**) for maximum **100 ml** or another type of equivalent cable
- Generally, any type of 4-wire cable with a 0.5 mm section is accepted. **Telephone cables** type **TCYY - 2x2x0.5-24 AWG** (max. 30ml); **TCYY - 3x2x0.5-24 AWG** (max. 50ml); **TCYY - 4x2x0.5-24 AWG** (max. 100ml) can also be used.



*Important:

- Maintain the same colors for the same connections.

Example: **+U** = Red, **C/D** = Blue, **GND** = Black, **Vin/Vout** = Green.

- For electrical safety reasons, we recommend installing an earthing cable between the panel and the SCU, connected to an earth grounding (ISO - IEC 60950-1:2005)

Option 3) UTP cat5e (AWG24) or UTP cat6e (AWG23), for maximum 250 lm

The wires will be arranged as per the below table:

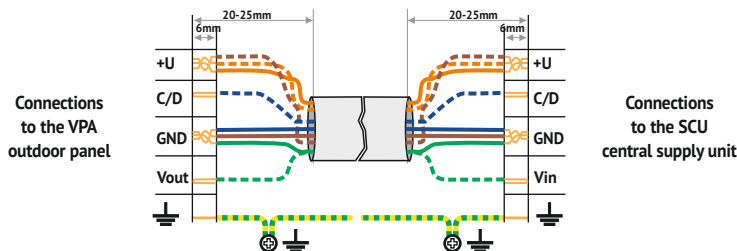

4.1 EN Installation of the advanced Video Outdoor Panel (VPA)

STEP 1

- Mounting on the wall - Flush

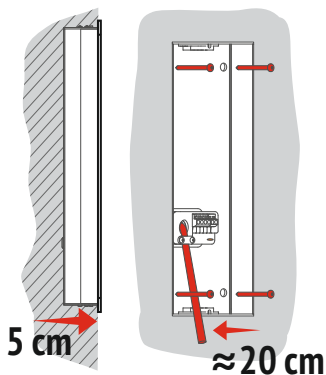

STEP 2

- Mounting on the wall - Surface

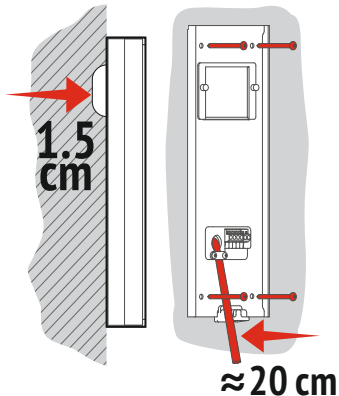

EN
3

- STEP 3
- Only for maximum 8 fam. video outdoor panels
 - Unmount the module and add name labels

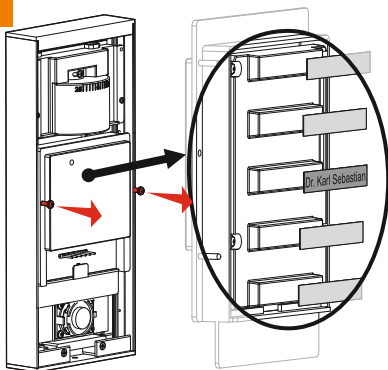

STEP 4

- Mount back the family name module

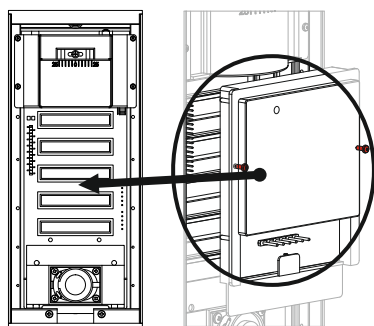

STEP 5

- Signaling of video monitoring: JP1 on RED LED position
- No video monitoring signaling: JP1 on 0 position
- Setting of image recording on DVR from the outdoor panel, with JP2: DVR
- Video camera angle adjustment. (The video camera will be oriented towards the entrance door/gate!).

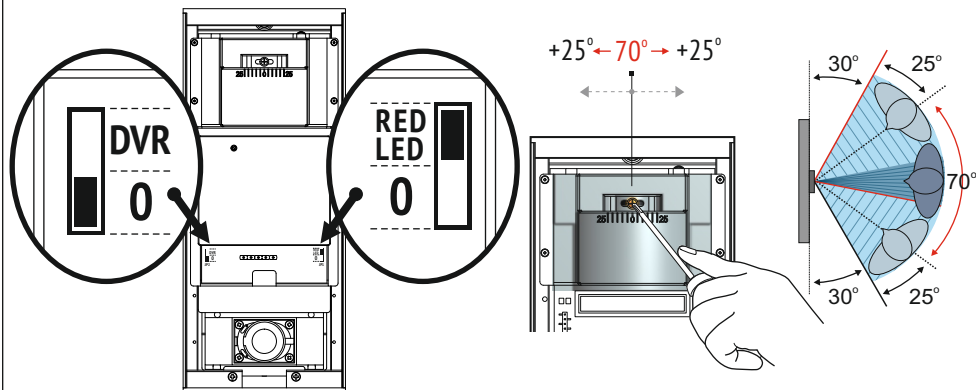

4.2 EN Electrical connections diagram for the advanced Video Outdoor Panel (VPA)

STEP 1

- Electrical connections in the panel

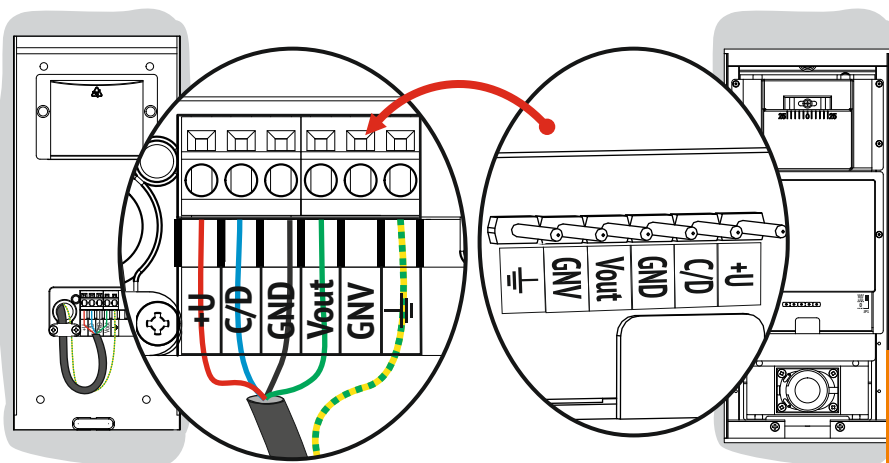

GNV will not be connected!

EN
4

STEP 1.1

- Mounting the outdoor panel on the wall

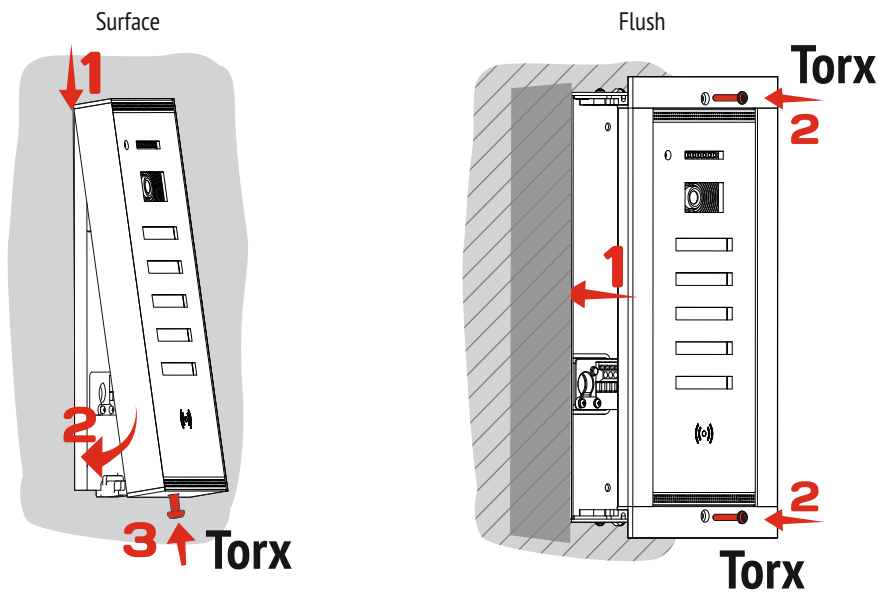

Important: For both types of mounting, the Torx screws for fastening the outdoor panels on the wall will be very well tightened, to prevent the anti-theft alarm sensor from setting off.

4.3 EN Electrical connections diagram for 1 and 2-family residences

VPA (address 1)

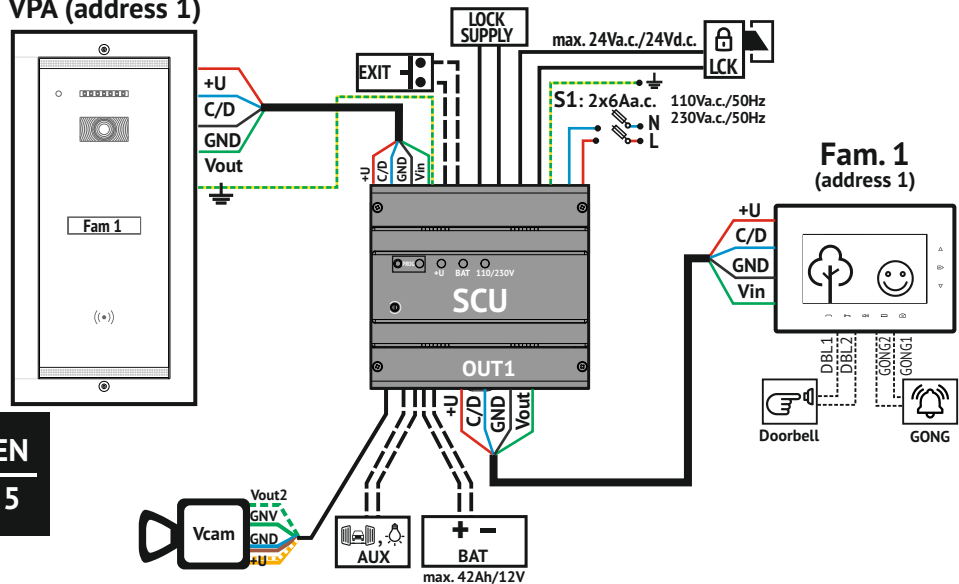

EN
5

VPA (address 1)

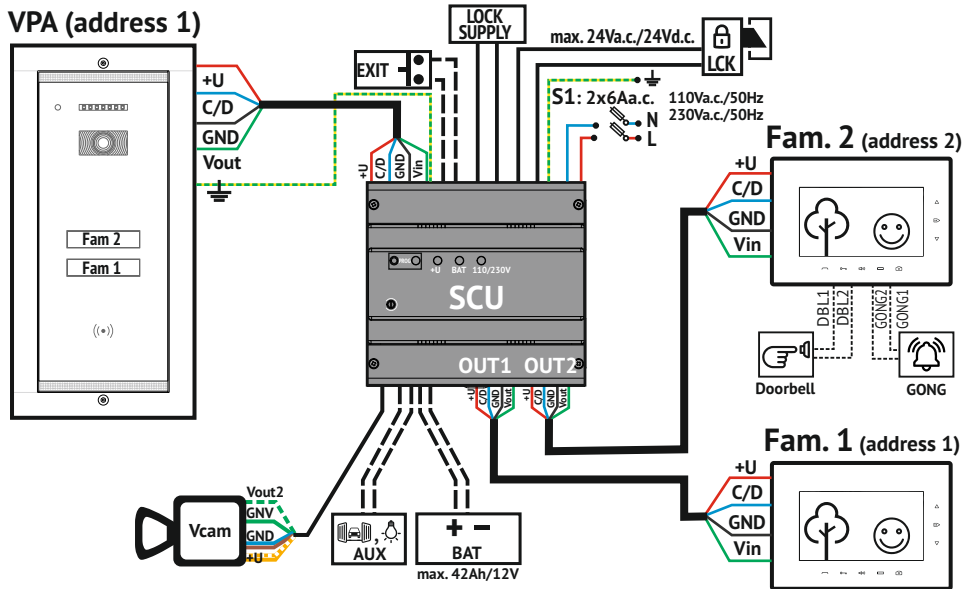

Note: • For residences with 1 family and one entrance (entrance 1), the outdoor panel has address 1, which is set by the producer.

- For multiple entrances: Entrance 2, Entrance 3, Entrance 4, panels 2, 3 and 4 will be programmed according to the procedure in Ch. 4.6.

Note: • Any type of TL terminal can be mounted indoors.

- For Fam. 1, the terminal has address 1, which is set by the producer.
- The additional terminals mounted in parallel will have the address of the main terminal
- For Fam. 2, the terminal will be programmed with address 2. See Ch. 6 of the user manual for TL audio-video terminals.

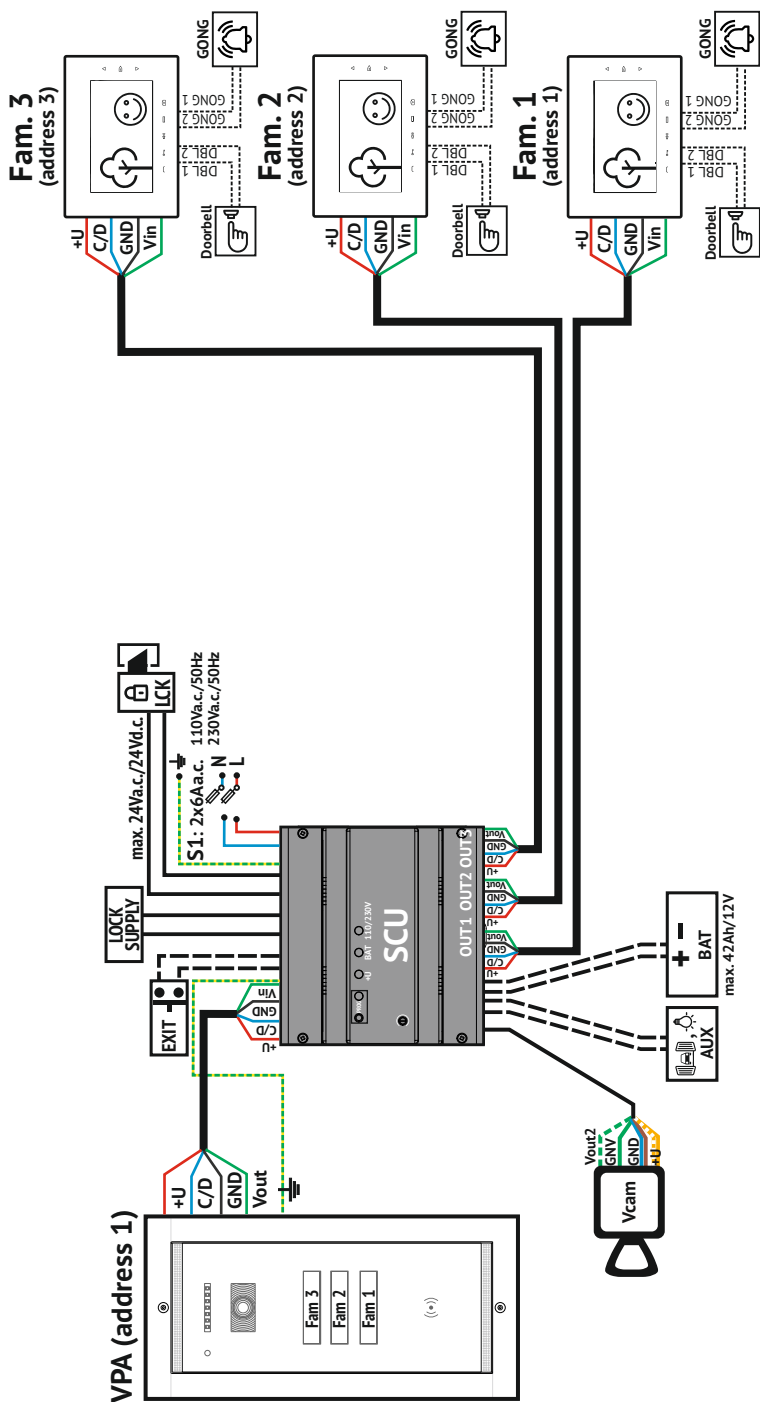

Note:

- For residences with **3 families** and one entrance (**entrance 1**), the outdoor panel has **address 1**, which is set by the producer.
- For multiple entrances: **Entrance 2**, **Entrance 3**, **Entrance 4**, panels **2**, **3** and **4** will be programmed according to the procedure in **Ch. 4.6**.

Note:

- Any type of **TL** terminal can be mounted indoors.

- For **Fam. 1**, the terminal has **address 1**, which is set by the producer.
- The additional terminals mounted in parallel will have the address of the main terminal
- For **Fam. 2** and **Fam. 3**, the terminal will be programmed with **address 2**, respectively **address 3**. See **Ch. 6** of the user manual for **TL** audio-video terminals.

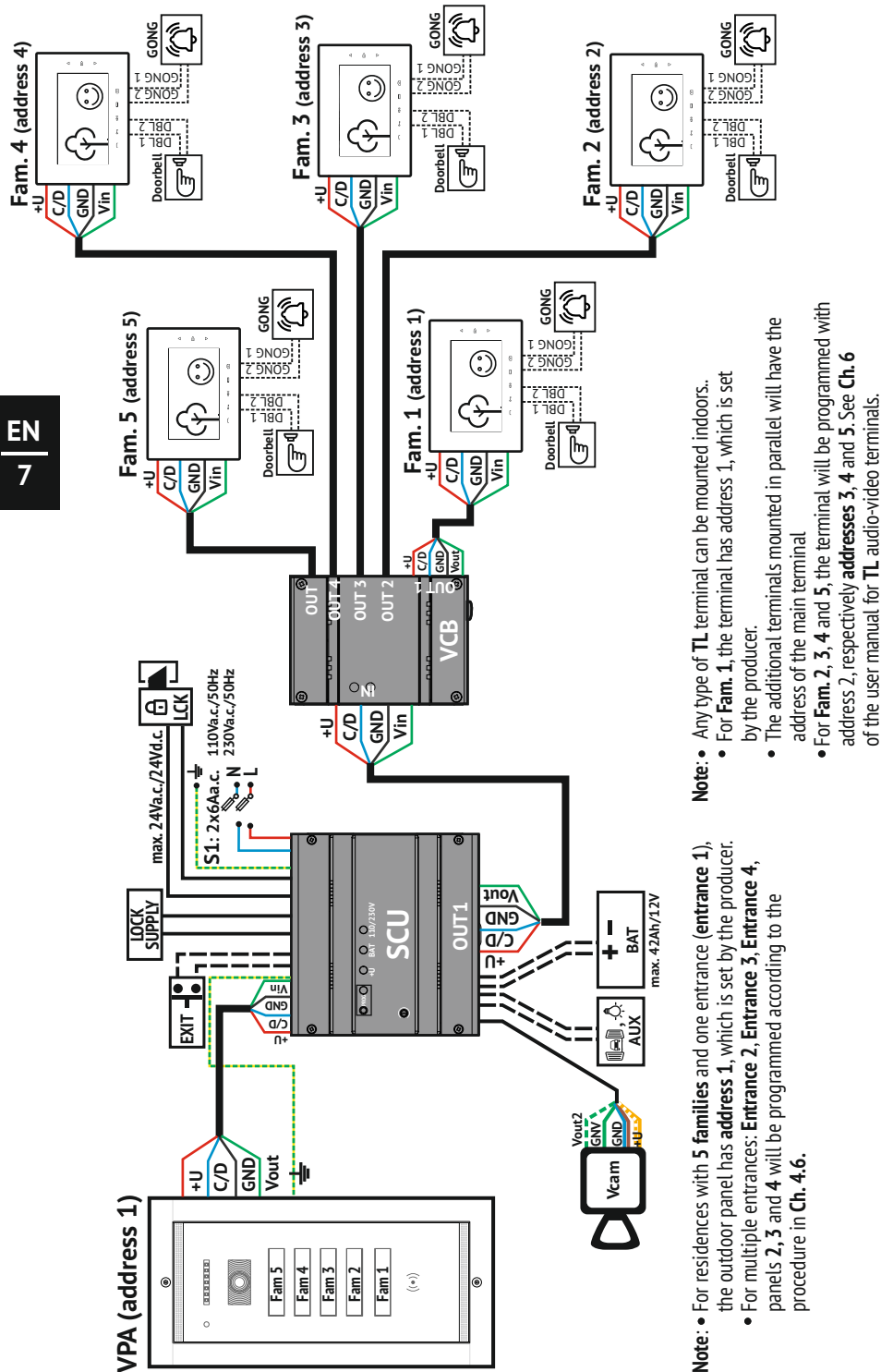

Note:

- For residences with 5 families and one entrance (entrance 1), the outdoor panel has address 1, which is set by the producer.
- For multiple entrances: Entrance 2, Entrance 3, Entrance 4, panels 2, 3 and 4 will be programmed according to the procedure in Ch. 4.6.

Note:

- Any type of TL terminal can be mounted indoors.
- For Fam. 1, the terminal has address 1, which is set by the producer.
- The additional terminals mounted in parallel will have the address of the main terminal
- For Fam. 2, 3, 4 and 5, the terminal will be programmed with address 2, respectively addresses 3, 4 and 5. See Ch. 6 of the user manual for TL audio-video terminals.

Electrical connections diagram for multiple parallel panels (more entrances in a building)

Important: One **VPA** outdoor panel and one **SCU** central unit will be mounted at each entrance.

The programming of the addresses for the panels connected in parallel is done as follows:

- The **VPA1** panel keeps **address 1**, which is set from the factory.
- The **VPA2** panel with **address 2** → Long press the **PROG.** button at **SCU 2** → Long touch the **Fam.1** key at the **VPA2** panel. → long beep → Short touch the **Fam.1** key, twice → **Two short beeps** confirmation.
- The **VPA3** panel with **address 3** → Long press the **PROG.** button at **SCU 3** → Long touch the **Fam.1** key at the **VPA3** panel. → long beep → Short touch the **Fam.1** key, three times → **Three short beeps** confirmation.
- The **VPA4** panel with **address 4** → Long press the **PROG.** button at **SCU 4** → Long touch the **Fam.1** key at the **VPA4** panel. → long beep → Short touch the **Fam.1** key, four times → **Four short beeps** confirmation.

Note: After the beep confirmation of the new address in the panel, go to the SCU of the panel and short press the **PROG.** button. The programming of the address is finished.

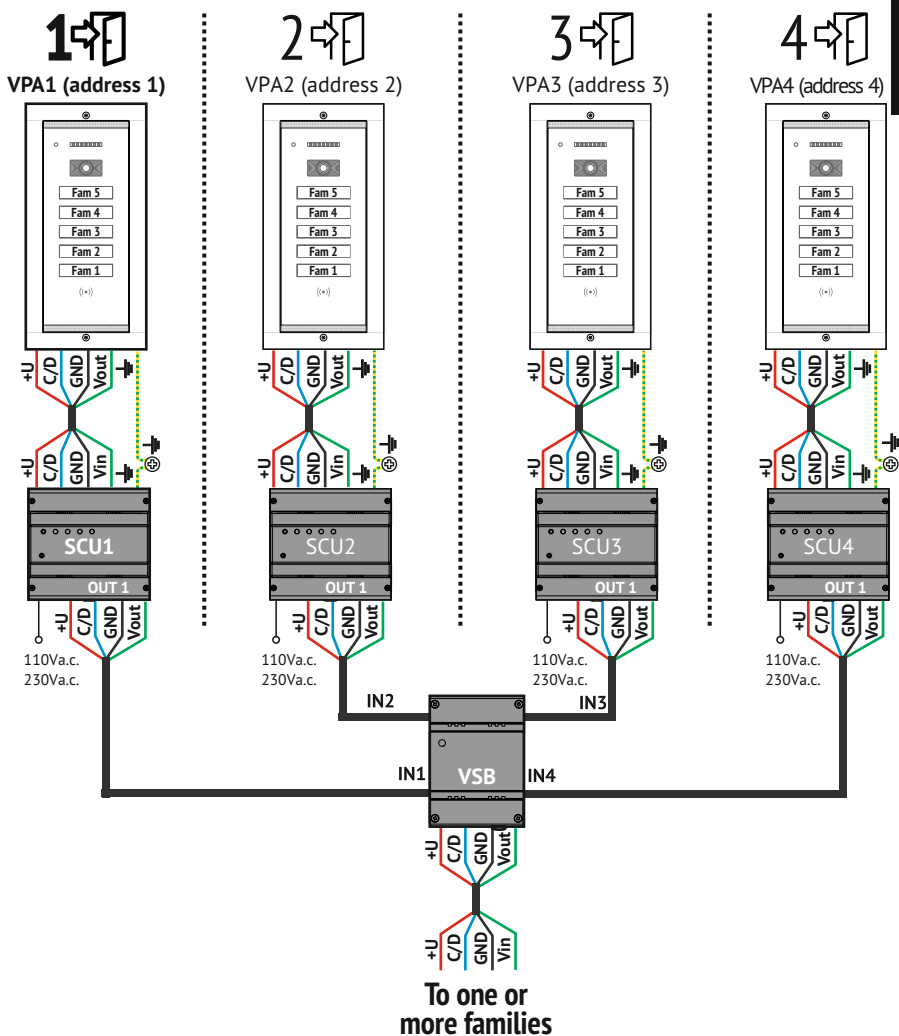

5 EN Use of the Video Outdoor Panels

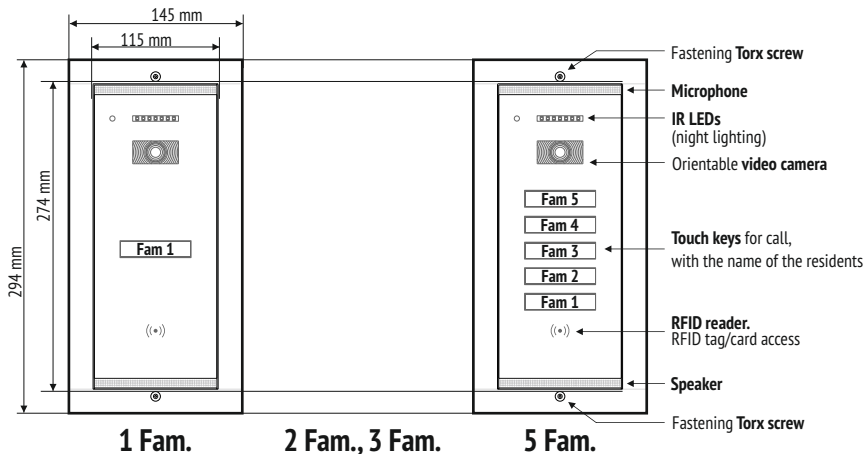

EN
9

1. STAND-BY: The call keys with the name of the residents are permanently backlit during night. The Red LED blinks permanently.

Note: The Red LED can be disabled through jumper JP1 (RED LED) on the board of the keyboard, when the name labels are added.

2. CALL: Touch the key corresponding to the name of the family you are looking for. The call is acoustically signaled with a ding-dong. Each touch of the key reinitiates the call.

3. TALK: If the resident answers, talk is initiated. The maximum duration of the talk is 2 min.

4. END OF TALK: - After 1 min. from the call, if the resident does not answer.
- At 10 sec. after the door/gate is opened.
- Immediately, if the resident decides to end the talk without opening the door/gate.

5. ACCESS: The door/gate will be open during the time set at the SCU (maximum 10 sec.). Access granting is acoustically signaled through a confirmation beep sequence.

6. RFID TAG/CARD ACCESS: If you program the RFID tags/cards in the outdoor panel, each resident of the building has access using the secured RFID tag/card from BELLCOME. Approach the tag/card to the RFID ((•)) area marked on the outdoor panel. The access is signaled acoustically, through a confirmation beep sequence, and visually - the ((•)) symbol blinks white.

5.1 EN Manual programming of the RFID TAGs/CARDS in the panel

• At the moment of the delivery from the factory, the **TL** video outdoor panels do not have access tags/cards memorized. In order to have access in the building after installation, it is mandatory to program the RFID tags/cards in the outdoor panel.

• During programming the installation has to be connected to the grid (110V/230Va.c.) and fully operational.

1. Go to the place where the **SCU** central unit of the installation is mounted. Long press (3 sec.) the **PROG** button on the **SCU**. The Red LED turns on.

2. Take the RFID tags/cards to the outdoor panels. To program them, approach every tag/card for one second to the RFID ((•)) area of the outdoor panel. For each programmed tag/card, the panel issues two short beeps. Repeat this step for programming all the RFID tags/cards.

3. Go to the place where the **SCU** central unit of the installation is mounted. Short press the **PROG** button on the **SCU**. The Red LED turns off. The installation returns to normal functioning, successfully ending the programming mode.

5.2 EN Deleting the RFID access TAGs/CARDS from the panel

This procedure applies when you wish to **give up access with RFID tags/cards**. During the deletion of the **RFID tags/cards**, the installation has to be connected to the grid (110V/230Va.c.) and fully operational.

1. Go to the place where the **SCU** central unit of the installation is mounted. Long press (3 sec.) the **PROG** button on the **SCU**. The Red LED turns on. The installation enters programming mode:

2. To delete the RFID access tags/cards from the memory of the panel:
 - Long touch the **Fam. 1** key until the acoustic confirmation of the panel with a long beep.
 - Short touch the **Fam. 1** key 7 times. The panel issues two short confirmation beeps.
 - Immediately after, long touch (2-3 sec.) the **Fam. 1** key. All the codes of the RFID access tags/cards are deleted permanently. The action is acoustically confirmed by a long beep.
3. Go to the place where the **SCU** central unit of the installation is mounted. Short press the **PROG** button on the **SCU**. The Red LED turns off. The installation returns to normal functioning mode.
4. Optional: From the outdoor panel, check if the old RFID tags/cards grant access. When each RFID tag/card that has been deleted from the memory is approached to the panel, a low frequency beep will be issued.

5.3 EN Adding a new RFID access TAG/CARD in the panel

- This procedure applies when you wish to **add new RFID access tags/cards** in the outdoor panel.
1. Collect all the RFID tags/cards from all the people who have access in the building and prepare the new access tags/cards.
 2. First, follow the procedure described in **chapter 5.2** for deleting all the tags/cards from the memory of the panel.
 3. Follow the procedure described in **chapter 5.1**. In this case, when you perform **point 2** of **chapter 5.1**, it is mandatory to approach both the new access tags/cards, and the old tags/cards to the RFID area of the panel, for reprogramming.
 4. After performing **point 3** of **chapter 5.1**, check if access is granted for all the programmed and reprogrammed RFID access tags/cards.

EN
10

6 EN Maintenance of the video outdoor panels

- The **Touch Line** audio-video terminals must be kept away from water, lime or any liquid substances, blows, fumes, powders, dust etc.
- For cleaning the glass screens, use a clean cloth and a special solution for glass washing.
- In case of renovation activities, the entire surface of the panels will be protected with plastic foil.
- DO NOT undo the electrical connections of the video door phone installation components.
- DO NOT short-circuit the electrical connections of the video door phone installation components.

7 EN Warranty

- a. Warranty is granted according to the current legislation in the buyer's country of residence, based on the purchase documents.
- b. Warranty is granted for the hidden defects of the components used in production and in case of the system not functioning according to the present user manual.

WARRANTY IS NOT GRANTED FOR:

- c. Inappropriate installation and use.
- d. Deterioration, intentional blows.
- e. Unauthorized interventions to any of the components of the installation
- f. Theft, fire, natural disasters
- g. Lack of protection of the installation components in case of renovation activities.

ELECTRA Building Communications GmbH
Bischoffgasse 5/3-4, 1120 Wien - **AT**
☎ +43 1 810 20 99
✉ support@bellcome.com
🌐 www.bellcome.com

ELECTRA s.r.l
Bd. Chimiei nr.8, Iași - 700291 - **RO**
🌐 www.electra.ro

BELLCOME is a trademark of ELECTRA Group - No. 013502646 EUIPO - Alicante, Spain
BELLCOME is a trademark of ELECTRA Group - No. 1732510 MPI - Ciudad de Mexico, Mexico
ELECTRA is a trademark of ELECTRA Group - No. 008958332 EUIPO - Alicante, Spain
BELLCOME/ELECTRA products are registered as Industrial Models at EUIPO - Alicante, Spain

The products are
CE certified.



Certificate by
709

The products contain UL-compliant
printed circuit boards.



Certificate no. E307311

The products are manufactured under
Quality and Environment Management System

ISO 9001:2015
ISO 14001:2015

Certificates no. 73 100 4856, 73 104 4856
by TÜV HESSEN